



Griffco Valve Inc.

6010 North Bailey Ave, Suite 1B

Amherst, NY 14226

Phone: 716-835-0891 or 1-800-GRIFFCO

Fax: 716-835-0893 or 1-888-830-7979

Instruction Manual

Back Pressure Valves Pressure Relief Valves

Call 1 - 800 - GRIFFCO

Website: www.griffcovalve.com

INS 1002-2005

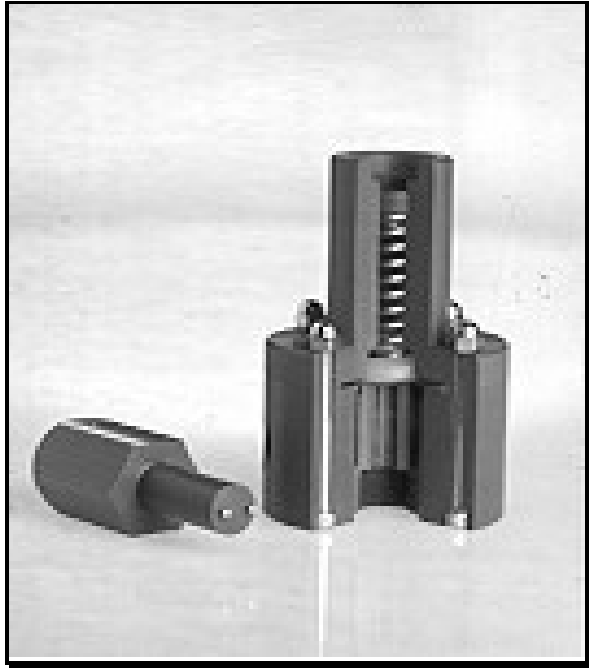

INTRODUCTION

GRIFFCO diaphragm back pressure valves are used to enhance the performance of chemical feed pumps and systems by providing a constant discharge head pressure. These valves also function as an anti-siphon valve. The diaphragm is held against the seat by the internal spring. Back pressure is adjustable from 10 - 150 psi via the adjustment screw. When the inlet pressure exceeds the preset pressure the diaphragm lifts off the seat and the chemical flows to the injection point. After each discharge stroke of the pump, as the pressure drops, the diaphragm reseats itself.

GRIFFCO diaphragm pressure relief valves are designed to protect chemical feed pumps and systems from overpressure caused by defective equipment or blockages in the chemical line.

The 3 port design allows chemical to flow through the valve via an internal chamber. When the pressure in the chemical line exceeds the preset pressure of the valve the diaphragm lifts off the seat and the chemical then flows out the bottom port back to the chemical tank. Relief pressure is adjustable from 10 - 150 psi via the adjustment screw in the top of the valve.

INSTALLATION

Back Pressure Valve:

Generally, the back pressure valve can be installed anywhere in the discharge line, provided there is some downstream pressure at the dosage point. If there is no downstream pressure the back pressure valve should be installed at the dosage point to prevent siphoning and drainage of the chemical line. All **GRIFFCO** valves are factory set at 50 psi, unless otherwise specified. Field adjustment is possible with the adjustment screw.

Back pressure valve performance will be enhanced with the installation of a pulsation dampener to smooth out the discharge / suction cycles of the pump. Thus, the diaphragm is free to float inside the valve chamber, minimizing the wear on the stress points of the diaphragm. For many low pressure applications dampeners without diaphragms are acceptable. These pulsation dampeners should be sized at 12 - 15 times the dosage volume of the pump head. For some applications diaphragm type dampeners are required. Generally speaking 5 to 10% dampening is sufficient. Consult with your pump manufacturer to get his recommendations.

Pressure Relief Valve:

Installation should be made as close to the chemical pump discharge valve as possible, without any equipment, especially shut-off valves, between the valve and the pump. Direction of flow must be across the valve, however the side of entry is not important. All **GRIFFCO** valves are factory set at 50psi, however field adjustment is possible with the adjustment screw.

The optimum installation for the relief valve is to vent the relief port back to the chemical tank, or directly to a containment area. However if this is not possible, the relief port can be piped back into the suction side of the pump. This will apply the suction head to the relief port. To compensate, divide the NPSH by 4 and add this pressure to the relief valve setting.

TYPICAL INSTALLATION

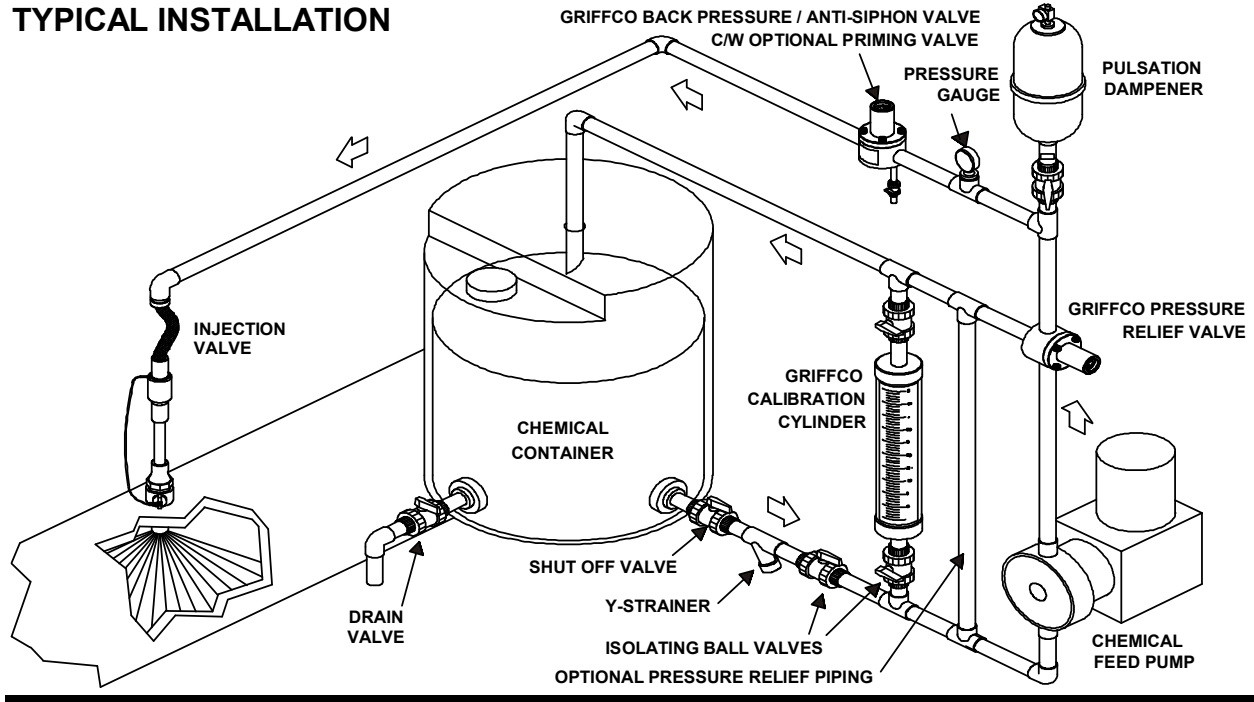

MAINTENANCE:

The pressure relief and back pressure valves were designed with minimizing the amount of maintenance required to keep the valves in operation. However, periodic replacement of the diaphragm is required. To facilitate inspection and replacement, the valve layout is such that removal of the diaphragm can be done without taking the valve out of the chemical line.

Caution: Ensure the system is not under pressure and that the chemical lines are flushed with water before disassembly.

Unscrew the pressure adjustment screw to remove the pressure from the diaphragm. Remove the 4 cap nuts and lift off the valve top. (On T-Series valves unscrew the valve top)

After the diaphragm and the valve seat have been inspected and replaced if necessary check the adjustment spring. Make sure there is no rust or corrosion. Replaced the spring and the spring bumper into the valve top and slide the top back over the four bolts. (On T-Series valves thread the valve top to the valve body)

Snug down the four cap nuts. (On T-Series . Snug hand tight then tighten ¼ turn) Screw in the tension adjuster to approximately the same position as it was prior to disassembly. If an exact pressure setting is required or a different pressure is desired a pressure gauge should be used to verify the setting. Pressure can be increased by turning the pressure adjustment screw clockwise.

DIMENSIONS:

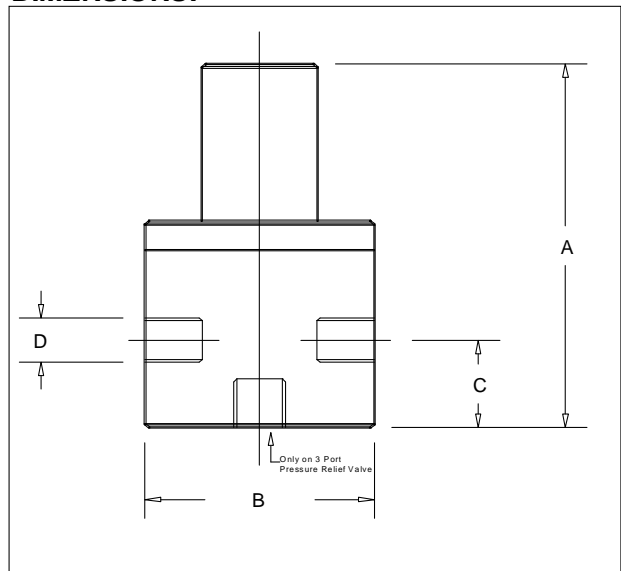

D	A	B	C
1/4"	3.50	2.375	0.750
3/8"	3.50	2.375	0.750
1/2" T-Series	4.60	2.375	1.125
1/2"	5.50	3.50	1.125
3/4"	5.50	3.50	1.125
1"	6.25	3.50	1.375
1 1/2"	9.00	4.50	2.10
2"	9.00	5.00	2.10

NOTE: Dimensions are general. See dimension sheets for exact sizes of various material valves.

PARTS LIST

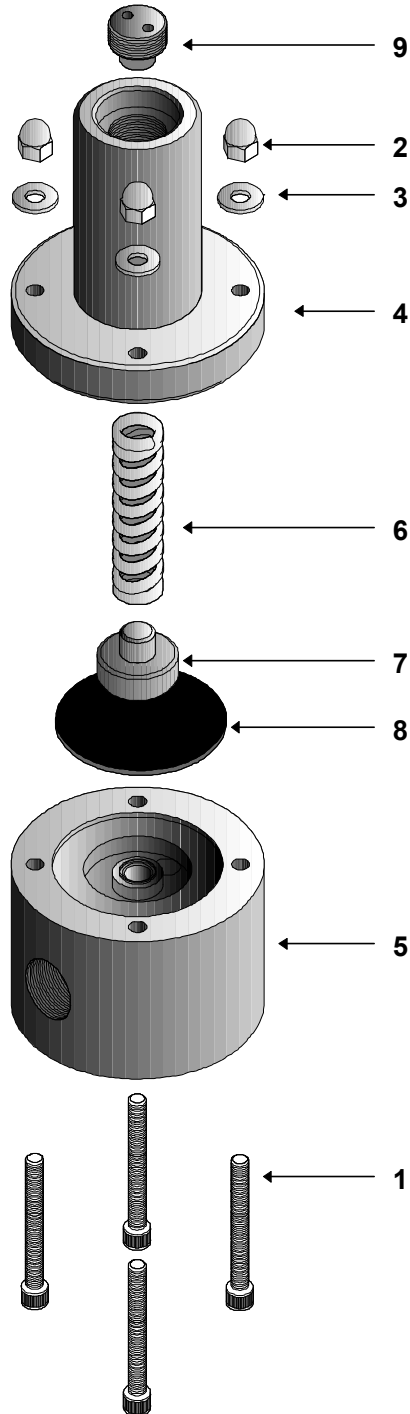

ITEM	DESCRIPTION	PART #
1	Bolt - 1/2 - 1" Plastic Valves . 1/4 - 20 X 2 3/4+	PV-00101
	Bolt - 1 1/2+- 2+Metal Valves . 5/16 . 18 X 1 1/2+	PV-00102
	Bolt - 1 1/2+- 2+Plastic Valves . 5/16 . 18 X 5+	PV-00105
	Bolt - 1/4" Plastic Valves . 10/32 x 1 3/4+	PV-00106
	Bolt - 1/4" Metal Valves . 10/32 X 3/4+	PV-00107
2	10/32 Cap hex nut	PV-00201
	1/4 - 20 Cap hex nut	PV-00202
	5/16 - 18 Cap hex nut	PV-00203
3	10/32 Flat washer	PV-00301
	1/4 Flat washer	PV-00302
	5/16 Flat washer	PV-00303
4	1/4" . 1/2+ T-Series Alloy Valve Top, Bolted . Noryl, Grey	PV-004011
	1/4" . 1/2+ T-Series Alloy Valve Top, Bolted . PVC, Orange	PV-004012
	1/4" . 1/2+ T-Series Alloy Valve Top, Bolted . PVC, Yellow	PV-004013
	1/4" . 1/2+ T-Series Alloy Valve Top, Bolted . PVC, Green	PV-004014
	1/4" . 1/2+ T-Series Valve Top, Threaded . Noryl, Grey	PV-004015
	1/4" . 1/2" T-Series Valve Top, Threaded . PVC, Orange	PV-004016
	1/4" . 1/2" T-Series Valve Top, Threaded . PVC, Yellow	PV-004017
	1/4" . 1/2" T-Series Valve Top, Threaded . PVC, Green	PV-004018
	1/2" . External Adjustment Valve Top . PVC (Tiberian)	PV-004019
	1/4" . 1/2" T-Series Alloy Valve Top . Coated Steel	PV-00402
	1/4" . 1/2+ T-Series Alloy Valve Top . 316 SS	PV-00403
	1/2" - 1" Valve Top . PVC, Grey	PV-004051
	1/2" - 1" Valve Top . PVC, Orange	PV-004052
	1/2" - 1" Valve Top . PVC, Yellow	PV-004053
	1/2" - 1" Valve Top . PVC, Green	PV-004054
	1/2" - 1" Valve Top . CPVC	PV-004055
	1/2" - 1" Valve Top - Steel	PV-00406
	1/2" - 1" Valve Top - 316 SS	PV-00407
	1 1/2+ - 2+ Valve Top; 5 1/2+Valves, PVC	PV-00408
	1 1/2+ - 2+ Valve Top; 5 1/2+Valves, Coated Steel	PV-00409
	1 1/2+ - 2+ Valve Top; 5 1/2+Valves, 316 SS	PV-00410
	1 1/2+ Valve Top; 4 1/2+Valves, PVC	PV-00411
1 1/2+ Valve Top; 4 1/2+Valves, Coated Steel	PV-00412	
1 1/2+ Valve Top; 4 1/2+Valves, 316 SS	PV-00413	
2+ Valve Top; 5+Valves, PVC	PV-00414	
2+ Valve Top; 5+Valves, Coated Steel	PV-00415	
2+ Valve Top; 5+Valves, 316 SS	PV-00416	
6	Pressure Spring - 1/4" . 1/2+ T-Series Valve; 0 . 150 psi	PV-00601
	Pressure Spring - 1/4" . 1/2+ T-Series Valve; 0 . 50 psi	PV-006011
	Pressure Spring - 1/4" . 1/2+ T-Series Valve; 50 . 350 psi	PV-006012
	Pressure Spring - 1/2" - 1" Valve; 0 . 150 psi	PV-00602
	Pressure Spring - 1/2" - 1" Valve; 0 . 50 psi	PV-006021
	Pressure Spring - 1/2" - 1" Valve; 50 . 350 psi	PV-006122
	Pressure Spring - 1/2" - 1" Valve; 0 . 100 psi, 316 SS	PV-006123
	Pressure Spring - 1 1/2+ - 2+Valve	PV-00603
7	Support Disc - 1/4" . 1/2+T-Series Valve, PP	PV-00701
	Support Disc - 1/4" . 1/2+T-Series Valve, 316 SS	PV-00702
	Support Disc . 1/2+ - 1" Valve, PP	PV-00705
	Support Disc . 1/2+ - 1" Valve, 316 SS	PV-00706
	Support Disc . 1 1/2+ - 2+Valve, PP	PV-00708
Support Disc . 1 1/2+ - 2+Valve, 316 SS	PV-00709	
8	Diaphragm - 1/4" . 1/2+ T-Series Valve - PTFE / EPDM	PV-00800
	Diaphragm - 1/4" . 1/2+ T-Series Valve - Viton	PV-00802
	Diaphragm - 1/4" . 1/2+ T-Series Valve - PTFE / Viton (High Temp)	PV-00803
	Diaphragm - 1/2" - 1" Valve - PTFE / EPDM	PV-00810
	Diaphragm - 1/2+ - 1+Valve . Viton	PV-00812
	Diaphragm - 1/2" - 1" Valve - PTFE / Viton (High Temperature)	PV-00813
	Diaphragm - 1 1/2+ . PTFE / EPDM . 3.25+Diameter	PV-00820
	Diaphragm - 1 1/2+ . Viton . 3.25+Diameter	PV-00821
	Diaphragm . 2+Valve . 3.5+Diameter	PV-00830
	Diaphragm . 2+Valve . Viton . 3.5+Diameter	PV-00831
9	Adjustment Screw - 1/4+ - 1+Valve PVC	PV-00900
	Adjustment Screw - 1/4+ - 1+Valve PVC, Slotted	PV-00902
	Adjustment Screw - 1/4+ - 1+Valve Coated Steel	PV-00901
	Adjustment Screw - 1/4+ - 1+Valve Coated Steel, Slotted	PV-00903
	Adjustment Screw - 1 1/2+ - 2+Valve PVC	PV-00920
	Adjustment Screw - 1 1/2+ - 2+Valve Coated Steel	PV-00921

ITEM	DESCRIPTION	BPV #	PRV #
------	-------------	-------	-------

5	1/4" Valve Body PVC	BPV-00501	PRV-00501
	1/4" T-Series Valve Body PVC,	BPV-005011	PRV-005011
	1/4" Valve Body PP	BPV-00502	PRV-00502
	1/4" T-Series Valve Body PP	BPV-005021	PRV-005021
	1/4" Valve Body PTFE	BPV-00503	PRV-00503
	1/4" T-Series Valve Body PTFE	BPV-005031	PRV-005031
	1/4" Valve Body PVDF	BPV-00504	PRV-00504
	1/4" T-Series Valve Body PVDF	BPV-005041	PRV-005041
	1/4" Valve Body 316 SS	BPV-00505	PRV-00505
	1/4" Valve Body Alloy 20	BPV-00506	PRV-00506
	1/4" Valve Body Hast C	BPV-00507	PRV-00507
	1/4" Valve Body CPVC	BPV-00508	PRV-00508
	1/4" T-Series Valve Body CPVC	BPV-005081	PRV-005081
	3/8" Valve Body PVC	BPV-00561	PRV-00561
	3/8+T-Series Valve Body PVC,	BPV-005611	PRV-005611
	3/8" Valve Body PP	BPV-00562	PRV-00562
	3/8" T-Series Valve Body PP	BPV-005621	PRV-005621
	1/4" Valve Body PTFE	BPV-00563	PRV-00563
	3/8" T-Series Valve Body PTFE	BPV-005631	PRV-005631
	3/8" Valve Body PVDF	BPV-00564	PRV-00564
	3/8" T-Series Valve Body PVDF	BPV-005641	PRV-005641
	3/8" Valve Body 316 SS	BPV-00565	PRV-00565
	3/8" Valve Body Alloy 20	BPV-00566	PRV-00566
	3/8" Valve Body Hast C	BPV-00567	PRV-00567
	3/8" Valve Body CPVC	BPV-00568	PRV-00568
	3/8" T-Series Valve Body CPVC	BPV-005681	PRV-005681
	1/2" Valve Body PVC	BPV-00511	PRV-00511
	1/2" T-Series Valve Body PVC	BPV-005111	PRV-005111
	1/2" Valve Body PP	BPV-00512	PRV-00512
	1/2" T-Series Valve Body PP	BPV-005121	PRV-005121
	1/2" Valve Body PTFE	BPV-00513	PRV-00513
	1/2" T-Series Valve Body PTFE	BPV-005131	PRV-005131
	1/2" Valve Body PVDF	BPV-00514	PRV-00514
	1/2" T-Series Valve Body PVDF	BPV-005141	PRV-005141
	1/2" Valve Body 316 SS	BPV-00515	PRV-00515
	1/2" T-Series Valve Body 316 SS	BPV-005151	PRV-005151
	1/2" Valve Body Alloy 20	BPV-00516	PRV-00516
	1/2" T-Series Valve Body Alloy 20	BPV-005161	PRV-005161
	1/2" Valve Body Hast C	BPV-00517	PRV-00517
	1/2" T-Series Valve Body Hast C	BPV-005171	PRV-005171
	1/2" Valve Body CPVC	BPV-00518	PRV-00518
	1/2" T-Series Valve Body CPVC	BPV-005181	PRV-005181
	3/4" Valve Body PVC	BPV-00521	PRV-00521
	3/4" Valve Body PP	BPV-00522	PRV-00522
	3/4" Valve Body PTFE	BPV-00523	PRV-00523
	3/4" Valve Body PVDF	BPV-00524	PRV-00524
	3/4" Valve Body 316 SS	BPV-00525	PRV-00525
3/4" Valve Body Alloy 20	BPV-00526	PRV-00526	
3/4" Valve Body Hast C	BPV-00527	PRV-00527	
3/4" Valve Body CPVC	BPV-00528	PRV-00528	
1" Valve Body PVC	BPV-00531	PRV-00531	
1" Valve Body PP	BPV-00532	PRV-00532	
1" Valve Body PTFE	BPV-00533	PRV-00533	
1" Valve Body PVDF	BPV-00534	PRV-00534	
1" Valve Body 316 SS	BPV-00535	PRV-00535	
1" Valve Body Alloy 20	BPV-00536	PRV-00536	
1" Valve Body Hast C	BPV-00537	PRV-00537	
1" Valve Body CPVC	BPV-00538	PRV-00538	
1 1/2" Valve Body PVC	BPV-00541	PRV-00541	
1 1/2" Valve Body PP	BPV-00542	PRV-00542	
1 1/2" Valve Body PTFE	BPV-00543	PRV-00543	
1 1/2" Valve Body PVDF	BPV-00544	PRV-00544	
1 1/2" Valve Body 316 SS	BPV-00545	PRV-00545	
1 1/2" Valve Body Alloy 20	BPV-00546	PRV-00546	
1 1/2" Valve Body Hast C	BPV-00547	PRV-00547	
1 1/2" Valve Body CPVC	BPV-00548	PRV-00548	
2" Valve Body PVC	BPV-00551	PRV-00551	
2" Valve Body PP	BPV-00552	PRV-00552	
2" Valve Body PTFE	BPV-00553	PRV-00553	
2" Valve Body PVDF	BPV-00554	PRV-00554	
2" Valve Body 316 SS	BPV-00555	PRV-00555	
2" Valve Body Alloy 20	BPV-00556	PRV-00556	
2" Valve Body Hast C	BPV-00557	PRV-00557	
2" Valve Body CPVC	BPV-00558	PRV-00558	