

# DataSheet

## Series AA

### Electronic Metering Pumps

### Configuration Data

Model AA **9** **4** **1** - **358SI**

#### Control Code

9 --- Microprocessor/Instrument Responsive: External 4-20mA or pulse + or x direct; manual stroke length control.

Note: Manual and instrument responsive models are available in Roytronic® A Series. See Data Sheet 1997

#### Output/Size Code

4 --- 0.58 GPH (2.2 l/h) --- 250 psi - (17.2 Bar)  
 5 --- 1.00 GPH (3.8 l/h) --- 110 psi (7.6 Bar)  
 6 --- 2.00 GPH (7.6 l/h) --- 50 psi (3.5 Bar)  
 7 --- 0.42 GPH (1.6 l/h) --- 140 psi (9.7 Bar)

#### Voltage Code

1 --- 120 VAC, US Plug  
 2 --- 240 VAC, US Plug  
 3 --- 220-240 VAC, DIN Plug  
 5 --- 240-250 VAC, UK Plug  
 6 --- 240-250 VAC, Aust./NZ Plug  
 7 --- 220-240 VAC, Swiss Plug

#### Liquid End

See next page for complete liquid end specifications and selection.

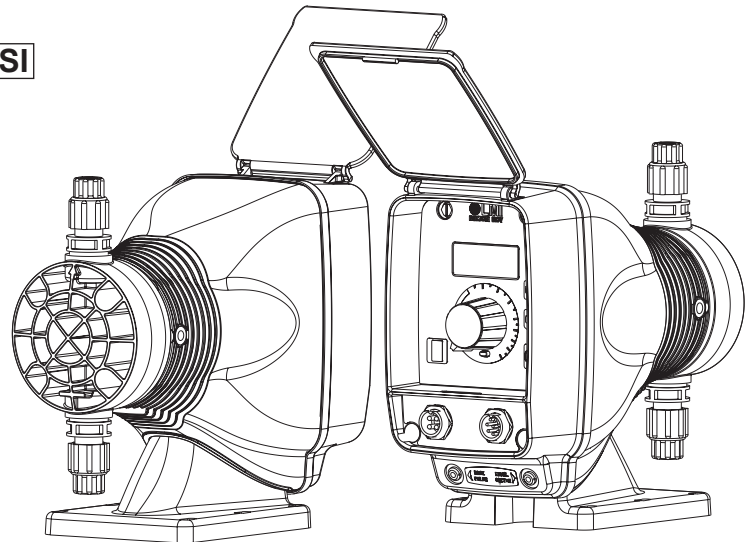

Certified to NSF/ANSI 61

Certified to NSF/ANSI Standard 50

### Dimensions

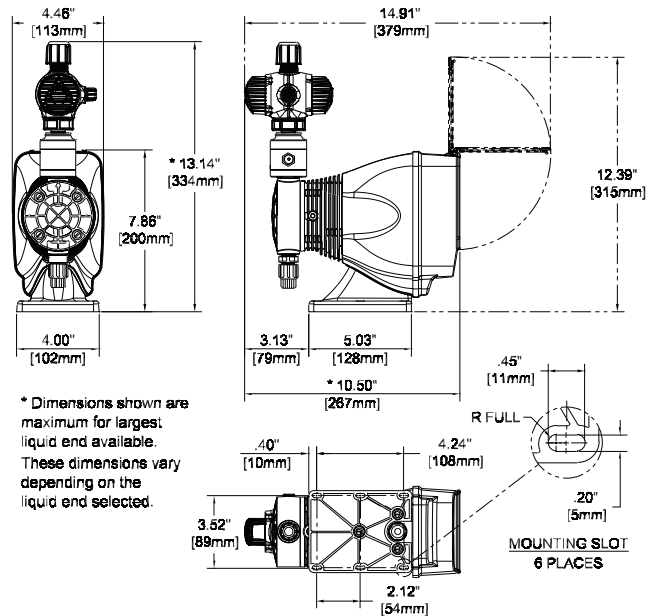

### Specifications

Series	Strokes Per Minute (Adjustable)		Stroke Length (Adjustable) Recommended Minimum	Average Input Power @ Max Speed	Shipping Weight
	Min	Max			
AA94* AA95* AA96*	1	100	20%	22 watts	10 lbs (4.55 kg)
AA97*	1	100	30%		

\*Series 9 pumps may be programmed for strokes per hour for lower outputs.



201 Ivyland Road  
 Ivyland, PA 18974 USA  
 TEL: (215) 293-0401  
 FAX: (800) 327-7563  
<http://www.lmipumps.com>

# Standard Liquid End Configuration Data & Materials of Construction

Drive Assembly	Liquid End No.	Size Code	Materials of Construction					Tubing & Connections	
			Head & Fittings	Balls	Liquifram™	Check Valve	Accessory	Discharge	Suction
AA97  - AA94  -	458SI	0.5	PVC / PVC	Ceramic	Fluorofilm™	PVDF / Polyprel®	4FV	PE .250" O.D.	
	459SI	0.5	Acrylic / PVDF	PTFE	Fluorofilm™	PVDF / Polyprel®	4FV	PE .250" O.D.	
	450SI	0.5	Acrylic / PVC	Ceramic	Fluorofilm™	PVDF / Polyprel®	4FV	PE .250" O.D.	
	358SI	0.5	PVC / PVC	Ceramic	Fluorofilm™	PVDF / Polyprel®	4FV	PE .250" O.D.	
	353SI	0.5	PVDF / PVDF	Ceramic	Fluorofilm™	PVDF / PTFE	4FV	PE .250" O.D.	
	352SI	0.5	PVDF / PVDF	Ceramic	Fluorofilm™	PVDF / Polyprel®	4FV	PE .250" O.D.	
	155HV	0.5	Polypropylene	316 S.S.	Fluorofilm™	PTFE		PE .5" O.D. Vinyl .938" O.D.	
	455SI	0.5	Polypropylene	Ceramic	Fluorofilm™	PTFE	4FV	PE .250" O.D.	
	156HV	0.5	Acrylic/PP	316 S.S.	Fluorofilm™	Viton		PE .5" O.D. Vinyl .938" O.D.	
	257	0.5	316 S.S.	316 S.S.	Fluorofilm™	316 S.S.		Pipe 1/4" NPT M	
AA95  -	498SI	0.9	PVC / PVC	Ceramic	Fluorofilm™	PVDF / Polyprel®	4FV	PE .375" O.D.	
	490SI	0.9	Acrylic / PVC	Ceramic	Fluorofilm™	PVDF / Polyprel®	4FV	PE .375" O.D.	
	499SI	0.9	Acrylic / PVDF	PTFE	Fluorofilm™	PVDF / Polyprel®	4FV	PE .375" O.D.	
	398SI	0.9	PVC / PVC	Ceramic	Fluorofilm™	PVDF / Polyprel®	4FV	PE .375" O.D.	
	392SI	0.9	PVDF / PVDF	Ceramic	Fluorofilm™	PVDF / Polyprel®	4FV	PE .375" O.D.	
	393SI	0.9	PVDF / PVDF	Ceramic	Fluorofilm™	PVDF / PTFE	4FV	PE .375" O.D.	
	85HV	0.9	Polypropylene	316 S.S.	Fluorofilm™	PTFE		PE .5" O.D. Vinyl .938" O.D.	
	86HV	0.9	Acrylic / PP	316 S.S.	Fluorofilm™	Viton		PE .5" O.D. Vinyl .938" O.D.	
	495SI	0.9	Polypropylene	Ceramic	Fluorofilm™	PTFE	4FV	PE .375" O.D.	
	297	0.9	316 S.S.	316 S.S.	Fluorofilm™	316 S.S.		Pipe 1/4" NPT M	
AA96  -	468SI	1.8	PVC / PVC	Ceramic	Fluorofilm™	PVDF / Polyprel®	4FV	PE .375" O.D.	
	460SI	1.8	Acrylic / PVC	Ceramic	Fluorofilm™	PVDF / Polyprel®	4FV	PE .375" O.D.	
	469SI	1.8	Acrylic / PVDF	PTFE	Fluorofilm™	PVDF / Polyprel®	4FV	PE .375" O.D.	
	368SI	1.8	PVC / PVC	Ceramic	Fluorofilm™	PVDF / Polyprel®	4FV	PE .375" O.D.	
	362SI	1.8	PVDF / PVDF	Ceramic	Fluorofilm™	PVDF / Polyprel®	4FV	PE .375" O.D.	
	363SI	1.8	PVDF / PVDF	Ceramic	Fluorofilm™	PVDF / PTFE	4FV	PE .375" O.D.	
	465SI	1.8	Polypropylene	Ceramic	Fluorofilm™	PTFE	4FV	PE .375" O.D.	
	75HV	1.8	Polypropylene	316 S.S.	Fluorofilm™	PTFE		PE .5" O.D. Vinyl .938" O.D.	
	76HV	1.8	Acrylic / PP	316 S.S.	Fluorofilm™	Viton		PE .5" O.D. Vinyl .938" O.D.	
	277	1.8	316 S.S.	316 S.S.	Fluorofilm™	316 S.S.		Pipe 1/4" NPT M	

## Output Information

Series	Gallons per Hour		Liters per Hour		mL/cc per Minute		mL/cc per Stroke		Maximum Injection Pressure
	Min	Max	Min	Max	Min	Max	Min	Max	
AA94*	0.001	0.58	0.004	2.2	0.07	37	0.07	0.37	250 psi (17.2 Bar)
AA95*	0.002	1.00	0.008	3.8	0.13	63	0.13	0.63	110 psi (7.6 Bar)
AA96*	0.004	2.00	0.015	7.6	0.25	126	0.25	1.26	50 psi (3.5 Bar)
AA97*	0.001	0.42	0.005	1.6	0.08	26	0.08	0.26	140 psi (9.7 Bar)

\* Minimum output is based on one stroke per minute. Minimum output can be reduced further in external mode. Series AA9 pumps may be programmed for strokes per hour for lower outputs.

## AutoPrime Liquid End Configuration Data Materials of Construction

Drive Assembly	Liquid End No.	Size Code	Head & Fittings	Balls	Liquifram	Check Valve	Accessory	Tubing & Connections
AA97	D50HI	0.5	Acrylic / PVC	Ceramic*	Fluorofilm™	PVDF / Polyprel®	4FV	PE 0.250" O.D.
AA94	D58HI	0.5	PVC / PVC	Ceramic*	Fluorofilm™	PVDF / Polyprel®	4FV	PE 0.250" O.D.
AA95	D90HI	0.9	Acrylic / PVC	Ceramic*	Fluorofilm™	PVDF / Polyprel®	4FV	PE 0.375" O.D.
	D98HI	0.9	PVC / PVC	Ceramic*	Fluorofilm™	PVDF / Polyprel®	4FV	PE 0.375" O.D.
AA96	D60HI	1.8	Acrylic / PVC	Ceramic*	Fluorofilm™	PVDF / Polyprel®	4FV	PE 0.375" O.D.
	D68HI	1.8	PVC / PVC	Ceramic*	Fluorofilm™	PVDF / Polyprel®	4FV	PE 0.375" O.D.

## Output Information - AutoPrime Liquid Ends (Liquid end models beginning with "D")

Series	Maximum Output				Maximum Pressure	
	GPH	Liters/hr	mL/cc per minute	mL/cc per stroke	PSI	Bar
AA94	0.42	1.6	26.5	0.26	250 psi	17.2
AA95	0.85	3.2	53.6	0.54	110 psi	7.6
AA96	1.85	7.0	116.7	1.17	50 psi	3.5
AA97	0.33	1.25	20.8	0.21	140 psi	9.7

AutoPrime liquid ends have 3 check valves: Suction on the bottom; Discharge on the front; AutoPrime bleed on the top. By design, a repeatable portion of the process fluid continuously bleeds through the top check valve to be returned to the chemical supply. The result is the assurance that any gas in the head is automatically relieved thus eliminating air-binding. The maximum output per the tables above is reduced to account for the continuous bleed.

See front page for voltage code specifications.

Plastic heads with tubing connection include 1/2" NPT and 1/2" BSP.

To specify black, UV resistant tubing, change 'I' to 'U'.

To specify 3FV, change 'S' to 'T'.

\* AutoPrime™ cartridge ball is Hastelloy.

**3FV** indicates that the pump is equipped with an LMI Three Function Valve (pressure relief, priming aid, line drain).

**4FV** indicates that the pump is equipped with an LMI Four Function Valve. This diaphragm type, anti-syphon/pressure relief valve is installed on the pump head. It provides anti-syphon protection and aids priming, even under pressure.

Fluorofilm™ is a copolymer of PTFE and PFA. Polyprel® is an elastomeric PTFE copolymer.

Polyprel is a registered trademark of the Milton Roy Company.

Fluorofilm and Liquifram are trademarks of the Milton Roy Company.

Viton® is a registered trademark of E. I. du Pont Company.